

Virtu 70 and 90 series

Coffee machine

Users manual

Model: Virtu 70 and 90
Machine type: 9CEC...

Revision B, English
Reference: 5DUCEK20

Your supplier is:

The manufacturer of the machine is:

De Jong Duke
Postbus 190
3360 AD SLIEDRECHT
The Netherlands
Telephone +31 (0) 184 496767
Fax: +31 (0) 184 416059



de JONG DUKE

www.dejongduke.nl
support@dejongduke.nl

Copyright © 2010, J.M. de Jong Duke automatenfabriek b.v.
All rights reserved.

Although this user manual has been put together with the utmost care, J.M. de Jong Duke automatenfabriek b.v. accepts no liability for inaccuracies or omissions. No liability is accepted for the consequences arising from operation of the equipment in accordance with the information contained in these instructions.

J.M. de Jong Duke automatenfabriek b.v. reserves the right to alter specifications at any time and without prior notification to the purchaser.

Preface

This user's manual is valid for the machine supplied by the manufacturer, including the options installed by the manufacturer. The manufacturer accepts no liability for any damage resulting from incorrect or improper use of the machine, or resulting from modifications that have not been authorised by the manufacturer.

This manual gives instructions on the operation and maintenance of the machine. Moreover, it gives solutions to simple malfunctions that may occur. The instructions in some paragraphs are meant only for persons who are trained in the operation and maintenance of the machine.

Besides this manual, a technical manual is also available. This technical manual gives directions for solving machine malfunctions and repairing the machine. For instructions on the installation of the machine, a separate installation manual is available.

Always use original parts from the manufacturer when the machine needs to be repaired.

Carefully read this instruction manual before you operate the machine.

Keep this manual in a safe place for possible later reference.

Only properly trained personnel may carry out repairs, install the machines or transport the machines.

The manual cannot be regarded as a replacement for training and instruction, but must be seen as an addition to the training, and as a reference work.

CONTENTS

1	SAFETY	4
1.1	SAFETY AND WARNINGS	4
1.2	STANDARDS AND NORMS	4
1.3	SAFETY RISKS.....	4
2	DESCRIPTION OF THE MACHINE	5
2.1	GENERAL	5
2.2	THE FRONT OF THE MACHINE.....	5
2.3	OVERVIEW OF THE MACHINE INTERIOR	5
2.4	TYPE PLATE	6
1.1	TECHNICAL SPECIFICATIONS	6
3	BEFORE USAGE	7
1.1.	INSTALLATION	7
1.2.	OPERATION SITE.....	7
1.3.	PUTTING THE MACHINE OUT OF ORDER	7
4	OPERATION	8
4.1	OPERATING THE MACHINE IN FREE VEND MODE.....	8
4.2	OPERATING THE MACHINE IN PAY MODE	8
4.3	JUG DISPENSING	8
5	MAINTENANCE AND FILLING	9
5.1	DAILY MAINTENANCE.....	9
5.2	WEEKLY MAINTENANCE	10
5.3	MONTHLY MAINTENANCE.....	11
5.4	PLACE SAFETY KEY.....	12
5.5	CLEANING CYCLE FOR COEX BREWER.....	13
5.6	FILL UP CANISTERS.....	14
5.7	REMOVAL OF THE BREWER.....	16
5.8	INSTALL THE BREWER.....	17
5.9	ASSEMBLING AND DISASSEMBLING THE MIXER	18
5.10	ASSEMBLING AND DISASSEMBLING THE TEA BREWER.....	22
6	FAILURE AND ERROR MESSAGES	23

1 Safety

1.1 Safety and warnings

- Keep this manual near the machine so the manual is immediately available.
- Do not use aggressive cleaning products or abrasives to clean (parts of) the machine.
- The water connection must conform to local regulations.
- Clean the machine with fresh hygienic water.
- The water system (boiler, pipes, etc.) may contain hot water, be careful!
- Do not shake the machine while in use.
- Do not use water in or near the machine unless the instructions contain explicit directions to the contrary.
- Do not use a damaged machine. If in doubt, contact your supplier first.
- Damaged water connection tubes may only be repaired by trained personnel.
- If a fault occurs, disconnect the machine from the electrical and water supplies.
- Do not lean on the door when open.
- Do not use an extension cord.
- Use the machine only in areas where trained personnel can monitor the operation.

1.2 Standards and norms

The machine is build according to CE norms

The machine complies with the following standards:

- Machine standard: 89/392/EEG
- EMC standard: 89/336/EEG,

The machine complies with the following norms:

- EN 292: safety of machines.
- UL and cUL 751: norm vending machines (only if sign is on type plate)

1.3 Safety risks

The important safety risks by using this machine:

- Hot drinks are dispensed from the machine; take care to avoid scalding yourself.
- If cups or jugs are not correctly placed, the machine will spill liquid down the front.
- The outlet of the machine may occasionally drip hot liquid even when the machine is not in use.

2 Description of the machine

2.1 General

The Machine is a compact semi-automatic machine for the preparation and vending of hot drinks. Your supplier can adjust the taste and sizes of the drinks.

2.2 The front of the machine

The machine can be operated using the operating panel on the door. By pushing one of the selection buttons on the screen, a product choice can be made. Before you make a choice, a cup must first be placed under the tap.

2.3 Overview of the machine interior

1. Coffee beans canister
2. Instant canisters
3. Lid
4. Door Lock
5. Mixing bowl
6. Waste bucket
7. External drip tray
8. Drip tray under brewer
9. Dispensing nozzles
10. CoEx brewer system
11. Basecabinet

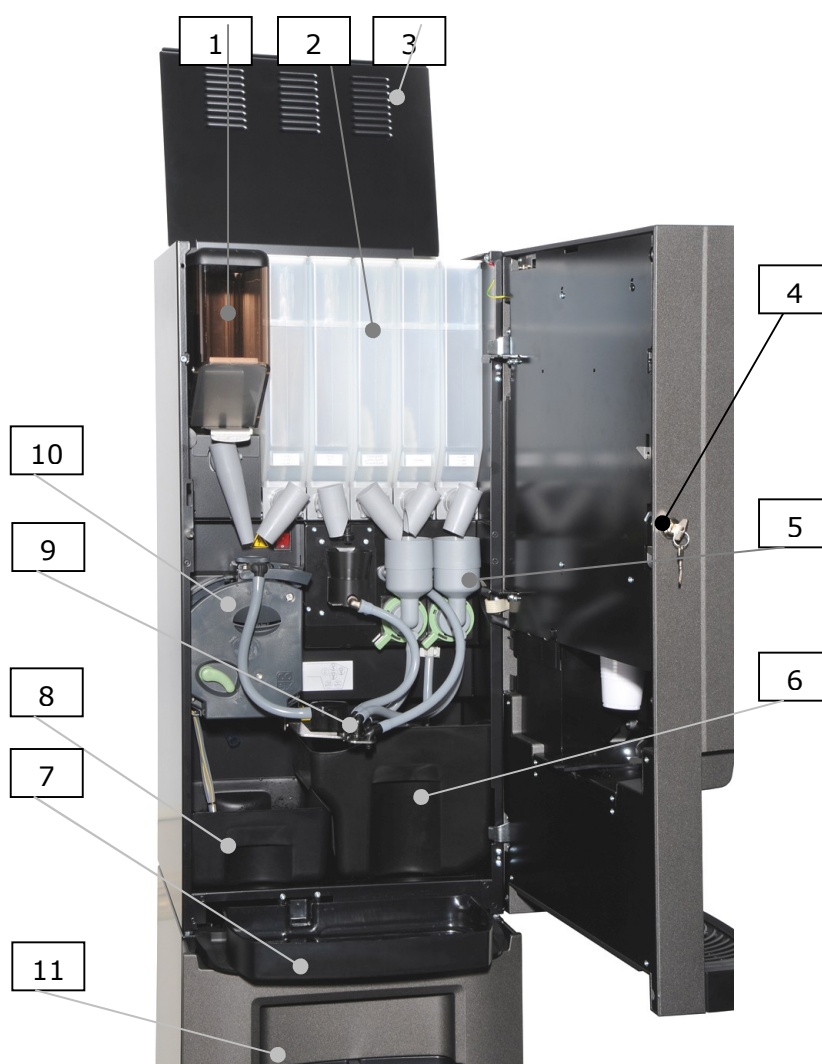

2.4 Type plate

The type plate is mounted on the inside of the machine, at the top left.
The following data are on the type plate:

- Name of manufacturer
- Serial number
- Type/model specification
- Date of construction
- Water connection



1.1 Technical specifications

Dimensions:

height	855 mm
width	465 mm
depth	530 mm

Weight (empty): +/- 55 kg

Electricity:

Mains supply:	230 Volt AC +/- 10%
Frequency:	50 Hz +/- 2%
Max. capacity:	2,4 kW

Water pressure:

Minimum:	90 kPa (0,9 bar)
Maximum:	600 kPa (6,0 bar)

Water connection: ¾ BSP connection

Sound pressure: < 70 dB(A)

Ambient temperature in use:	+5°C to +40°C
Ambient temperature in storage:	+10°C to +50°C

3 Before usage

1.1. Installation

Installation, transportation and adjustment of the machine is specialized work. Only properly trained service personnel should carry this out. For instructions about transportation, unpacking and installation of the machine, see the technical manual.

1.2. Operation site

These machines may only be used indoors, in a hygienic dry room, with a temperature between 5 and 40 degrees Celsius. Place the machine on a flat, stable surface.

1.3. Putting the machine out of order

If the machine will not be used for a long period of time (for example during the weekend,) it is recommended to turn off the water supply and the electricity (pulling the plug from the socket is sufficient). This will prevent unnecessary use of energy.

4 Operation

4.1 Operating the machine in free vend mode

1. Place a cup under the outlet on the cup stand.



All consumptions are dosed in the center of the cup stand except the hot chilled water.

2. Select your desired drink.
3. Follow the instructions on the screen.
4. After pressing the start button, the machine prepares your drink and dispenses it into the cup.
5. Your drink is ready after the beep and the message 'ready' is on the screen.

4.2 Operating the machine in pay mode

In pay mode first insert the required money and continue with step 1 of the free vend operation.

4.3 Jug dispensing

1. Move the cup stand upwards and place a jug under the outlet.
2. Press the jug button.
3. Select the drink and jug size
4. Press the start button.
5. The machine dispenses the selected drink into the jug.
6. Your drink is ready after the beep and the message 'ready' is on the screen.



5 Maintenance and filling

5.1 Daily maintenance

Failing to perform the daily maintenance negatively affects the quality of the products and can lead to malfunctioning of the machine.

1. Open the door of the machine.
2. Install the safety key (see paragraph: install safety key)

Flush mixers and brewer

3. Place a jug underneath the nozzle to collect the hot water.
4. Press the rinse daily button on the screen. Hot water from the boiler flows through the CoEx-brewer and mixers.
5. Repeat step 4 until clean water comes out of the machine.



Empty waste bucket and drip tray

6. Remove the drip tray, the cup stand and the grid.
7. Remove the drip tray under the brewer.
8. Rinse the drip trays, cup stand and grid in warm water.
9. Remove the wastebucket
10. Empty the bucket and rinse it in warm water.

Check if there are still enough ingredients in the canisters. If necessary fill up the canisters, following instructions in paragraph "Fill up canisters".

Clean the outside of the machine

11. Clean the outside of the machine with a soft damp cloth.
12. Install the drip trays, grid and cup stand.
13. Close the door of the machine, and leave the service mode.

Empty waste bucket and drip trays:

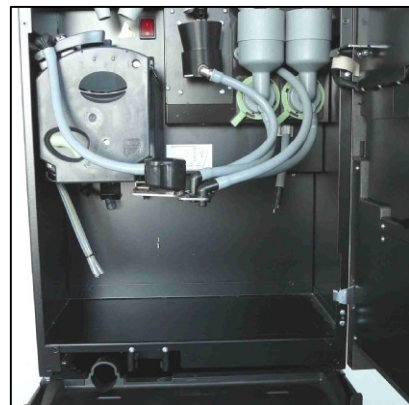

5.2 Weekly maintenance

Failing to perform the weekly maintenance negatively affects the quality of the products and can lead to malfunctioning of the machine.

1. Open the door of the machine.

Clean the mixing system

2. Remove the mixing system according to paragraph "*Disassembling the mixing bowl*".
3. Rinse out all loose parts of the mixing system in warm water.
4. Clean the parts of the mixing system that remain in the machine with a wet brush.
5. Mount the mixing system according to paragraph "*Assembling the mixing bowl*". Make sure that the parts are dry before you mount them.

Clean the tea brewer (if applicable)

6. Remove the tea system according to paragraph "*Disassembling the tea brewer*".
7. Rinse out all loose parts of the teabrewer in warm water.
8. Mount the tea brewing system according to paragraph "*Assembling the teabrewer*".

Check if there are still enough ingredients in the canisters. If necessary fill up the canisters, following instructions in paragraph "*Fill up canisters*".

Clean brewer

9. Place a jug underneath the nozzle to collect the hot water.
10. Install the safety key.
11. Press the "Weekly cleaning cycle brewer" button on the screen.
12. Follow the instructions in the screen:
 - a. Place tablet in brewer
 - b. Close door or place service key
 - c. Place 1 liter jug under outlet
 - d. Be careful: hot water flows out
 - e. Press button to run cleaning cycle
13. Hot water from the boiler is flowing through the CoEx-brewer.

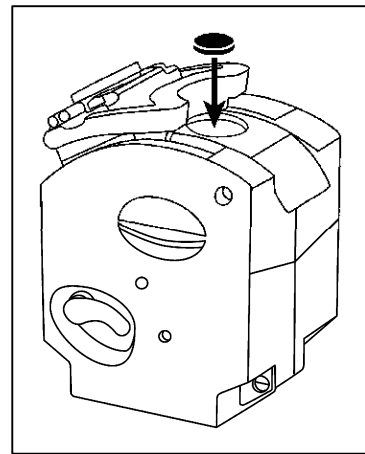

See paragraph "*cleaning cycle for CoEx brewer*" for detailed information.

Empty waste bucket and drip tray

14. Remove the drip tray, the cup stand and the grid.
15. Remove the drip tray under the brewer.
16. Rinse the drip trays, cup stand and grid in warm water.
17. Remove the wastebucket
18. Empty the bucket and rinse it in warm water.

Clean the outside of the machine

19. Clean the outside of the machine with a soft damp cloth.
20. Install the drip trays, grid and cup stand.
21. Close the door of the machine, and leave the service mode.

5.3 Monthly maintenance

Failing to perform the monthly maintenance work negatively affects the quality of the products and can lead to malfunctioning of the machine.

Apart from the weekly maintenance, the following tasks have to be performed monthly to ensure the machine operates correctly and optimal quality of the beverages.

Cleaning the canister with water

1. Remove the canister from the machine.
2. Remove the lid from the canister.
3. Empty the canister.
4. Rinse out the canister with warm water until all product residues are removed.
5. Dry the canister very thoroughly on the inside and outside.



If you fill the canister while it is not completely dry, the product may form lumps, which makes the system not usable anymore.

6. Fill the canister and place it back in the machine according to the procedure in paragraph "Fill up canisters".

Cleaning the CoEx brewer with water

1. Remove the CoEx Brewer from the machine according to the procedure in paragraph "Remove the brewer".
2. Rinse the brewer with warm water.
3. Place the CoEx back according to the procedure in paragraph "Install the brewer".

5.4 Place safety key

Insert the safety key and turn a quarter turn clockwise:

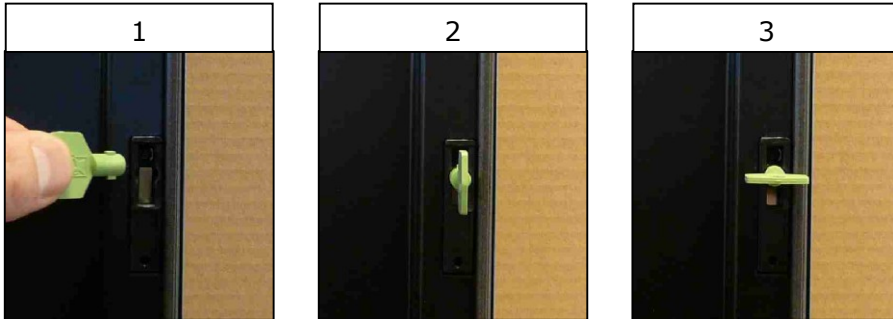

The machine is now powered up. Parts in the machine can move automatically and hot water can flow out. Be careful!

5.5 Cleaning cycle for CoEx brewer

Run the cleaning cycle for the CoEx brewer weekly using the CoEx cleaning tablet.

1. Open the door of the machine.
2. Press the *weekly cleaning cycle* button and follow the instructions on the screen:
 - a. Place cleaning tablet in brewer
 - b. Place service key.
 - c. Place a jug under the brewer outlet.
 - d. Press button to start.

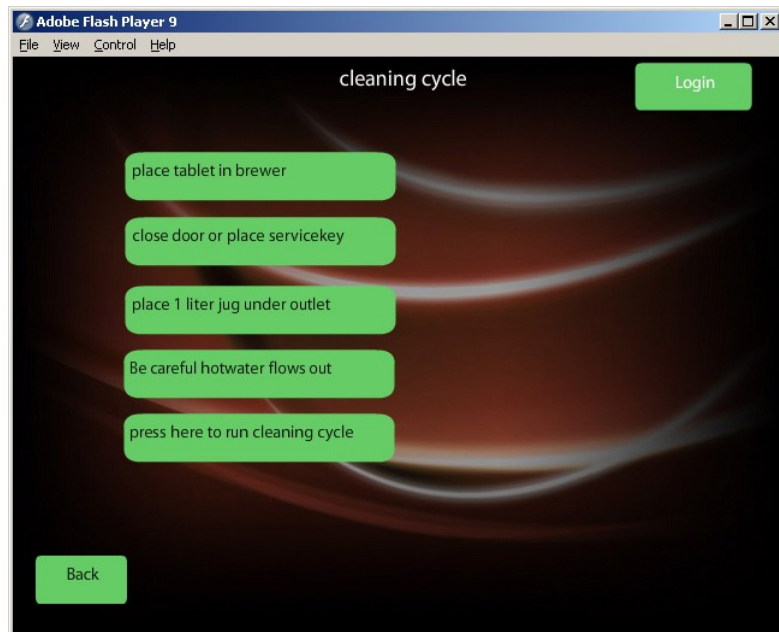

3. The cleaning cycle is started and takes ± 5 minutes. Wait till the cycle is finished.
4. Close the door and run a test consumption to test the machine.

! Not cleaning the brewer can cause the machine to malfunction!

Note:
Failure to clean the brewer weekly with the cleaning tablet delivered by the manufacturer will void the warranty on related parts.

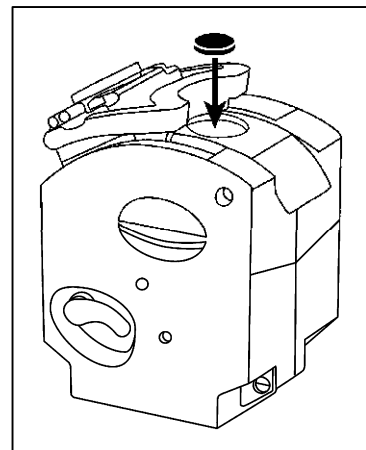

5.6 Fill up canisters

Do not fill up the canisters further than necessary for one or two days. This will keep the products fresh. Make sure that the canisters remain filled with a layer of at least 4-cm of product. Only use products that are recommended by the supplier of the machine.

Filling the canisters must be done outside the machine. To facilitate taking out the canisters, the topside of the machine can be flipped up (after opening the door).

Perform the following procedure to fill a canister:

1. Turn the nozzle of the canisters upwards.



2. Slightly lift up the canister at the front, until the positioning ridge comes out of the hole.



3. Pull the canister towards the front and take it out of the machine.



4. Fill the canister with the product indicated on the canister.

Place the lid back on the canister.



5. Place the canister back in the machine. Make sure the drive at the back of the canister fits well on the motor drive.

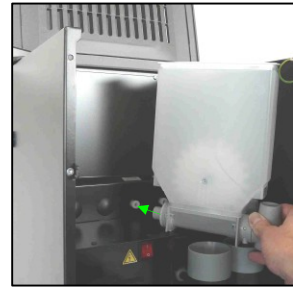

6. Push the canister at the front over the positioning ridge.



7. Turn the nozzle of the canisters downwards. Check the position of the nozzle of the canister. It must be positioned correctly above the brewer or mixing bowl.



5.7 Removal of the brewer

Removal of the brewer is necessary for performing maintenance. Only properly trained personnel may work on the brewer itself. Instructions for performing work on the brewer are described in the technical manual.

Carry out the following procedure for removal of the brewer:

1. Open the door of the machine.



2. Remove the outlet pipe from the brewer.



3. Push the green handle upwards and pull the brewer out off the machine at the same time.

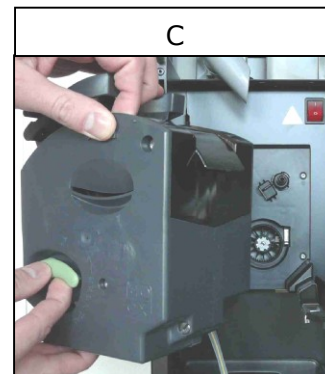
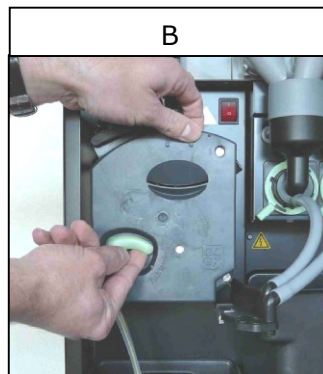
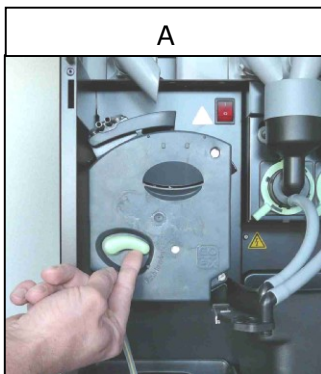

4. Ready.

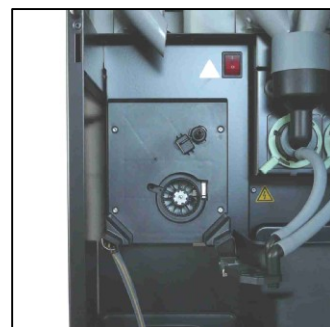

5.8 Install the brewer

Carry out the following procedure to replace the brewer:

1. Place the brewer in the bracket.

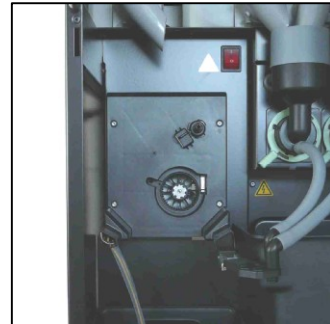

2. Push the brewer firmly in the machine till you hear "click" and the green handle is turned downwards in its home position.



Make sure that the green handle is in the down position. When the brewer isn't installed correctly the brewer can jump out of the fitting during a cycle.

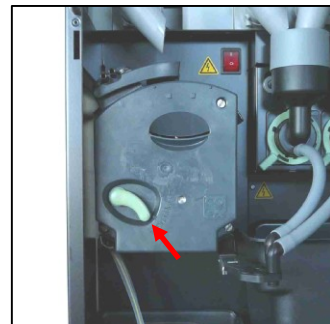

3. Place the tubes.

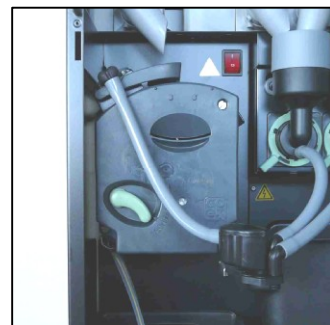

4. Check the function of the brewer by making a test drink. Place a cup under the outlet.

5.9 Assembling and disassembling the mixer

Disassembling the mixing system:

1. Remove outlet pipes from the mixers.

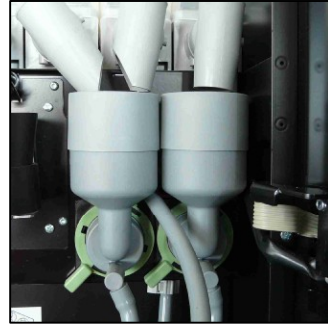

2. Turn the bayonet catch anti clock wise (approx. 10°).

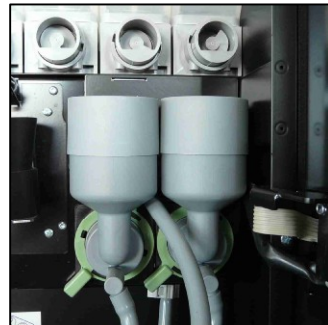

3. Remove the mixer house.

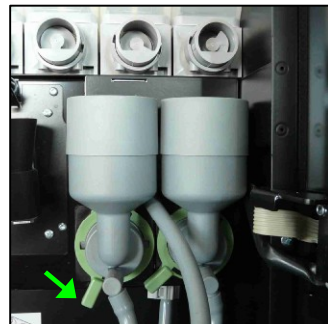

4. Pull the mixer parts towards you.

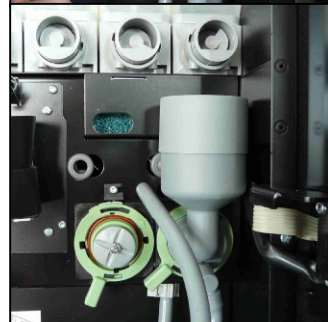

5. Pull the whipper blade towards you.

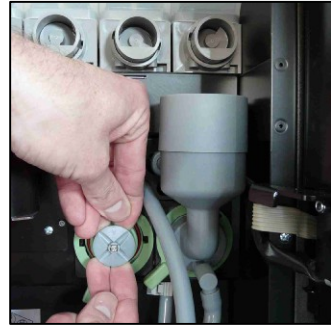

6. Turn the base plate counterclockwise and pull it towards you.

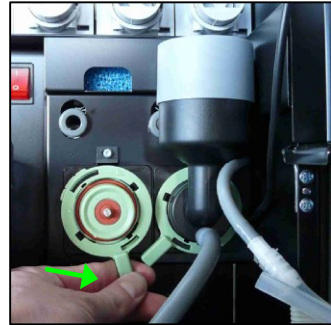

7. Ready

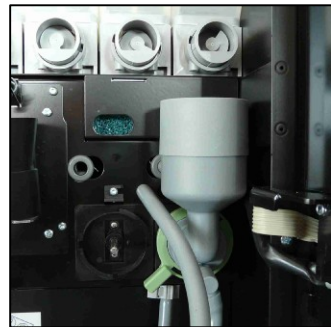

Assembling the mixing system:

1. Install the base plate.



2. Install the whipper blade.
Be sure that the arrow is at the flat side of the ax.

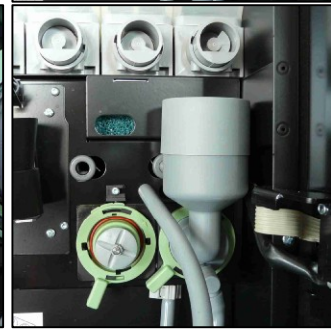
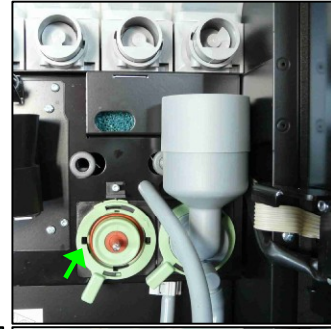

3. Install the mixer house.

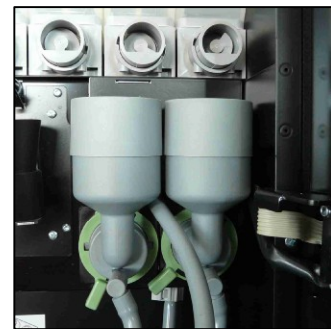

4. Turn the bayonet catch clockwise.

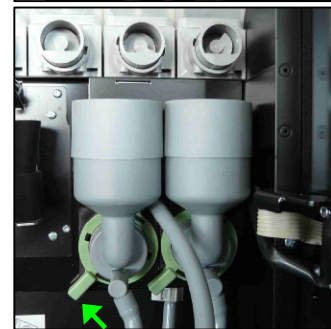

5. Install the outlet pipes on the canisters.

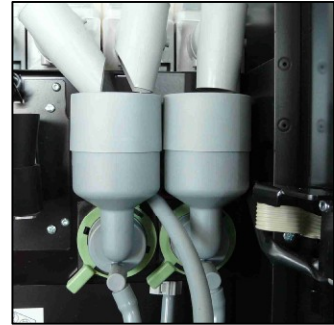

6. Ready.

5.10 Assembling and disassembling the tea brewer

Disassembling the tea brewer

Push the metal holder downwards and pull the tea brewer out of the metal bracket. Disassemble the tea brewer and clean the nylon screen.

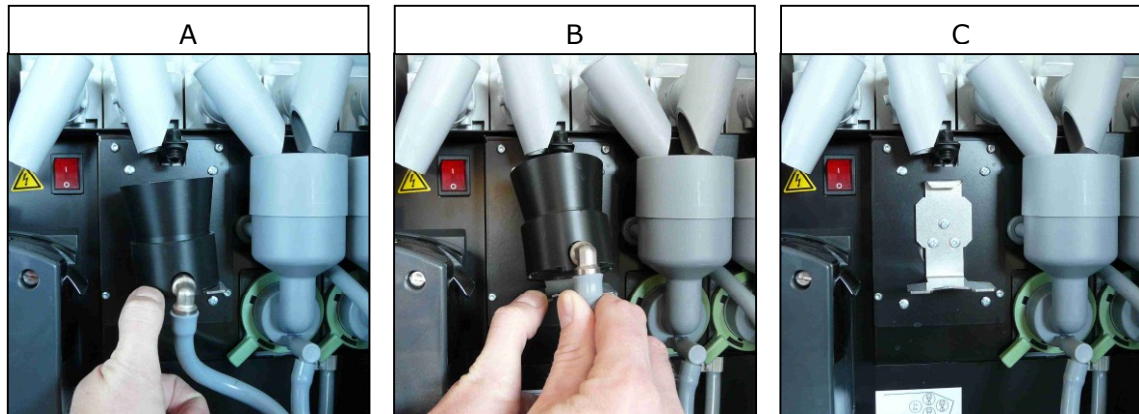

Assembling the tea brewer in reversed order

6 Failure and error messages

Always check whether an error message is shown on the display. If no error message is shown and the machine does not work correctly, you may find the possible cause and solution in the following table. For failures not mentioned in this manual, contact the service engineer.

Rinse brewer with tablet

The weekly cleaning cycle is required. Run the cleaning cycle and the message will disappear.

Brewer not in home position

The brewer is not installed correctly. Remove and replace the brewer following the procedure.

Communication error

Consult the service engineer

Cleaning Error

Cleaning cycle did not finish. Run the cleaning cycle again and finish it correctly.

Door open

Close door or install service key to run the machine.

Drip tray full

Empty the drip tray in front of machine and under the brewer make sure the probes are dry.

Enough water?

The brewer screens are dirty. Run the weekly cleaning cycle with a cleaning tablet.

Empty waste bucket

Empty the waste bucket.

Filling boiler

Wait until boiler is filled.

If message is still shown after 10 minutes, consult the service engineer.

Grinder blocked

Grinder is blocked and needs to be cleaned out.

Heating boiler 1 or WAIT, Heating boiler 2

Wait until boiler is heated.

If message is still shown after 10 minutes, consult the service engineer.

Install waste bucket

Install the waste bucket in the machine.

Mixer blocked

Clean the mixing bowl

No water connected

No water detected for more then 30 seconds. Open and close the machine door for restart.

Place cup left or Place cup right

Cup needs to be installed on the grid before the start buttons is available.

Water filter installed?

Consult the service engineer.

Replace water filter

Consult the service engineer

Shortcut temp.sensor

Consult the service engineer

Startup problem

Open and close the machine door for restart.

If message shows again, consult the service engineer

Tea brewer not in position

Consult the service engineer

Temp. sensor disconnected

Consult the service engineer.

Temp. boiler to high

Consult the service engineer

Water level to low

Consult the service engineer

Notes:

A series of 20 horizontal dashed lines for writing notes.