

*Nio*

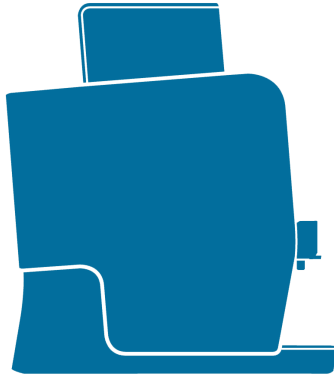





reddot award 2014  
winner

# Contents

<b>1</b>	<b>Safety</b>	<b>6</b>
1.1	Safety use	6
1.2	Installation	7
1.3	Maintenance	7
1.4	Extended down time	8
<b>2</b>	<b>Description of the machine</b>	<b>10</b>
2.1	General	10
2.2	The machine exterior and interior	10
2.3	Display and selections	10
2.4	Type plate	10
<b>3</b>	<b>Using the Nio</b>	<b>12</b>
3.1	Switch on	12
3.2	Switch off	12
3.3	Preparing a drink	12
3.4	Number selection	14
3.5	Filling the ingredients	14
3.6	Manual ground coffee insert	15
3.7	Connect the fresh milk	15
3.8	Service menu	17
<b>4</b>	<b>Information</b>	<b>18</b>
4.1	Reading out the counters	18

<b>5</b>	<b>Maintenance and cleaning</b>	<b>20</b>
5.1	Daily maintenance	20
5.2	Weekly maintenance	25
5.3	Monthly maintenance	34
5.4	Yearly maintenance (only for optional fresh milk system)	35
<b>6</b>	<b>Messages</b>	<b>36</b>
<b>7</b>	<b>Technical specifications</b>	<b>38</b>
<b>8</b>	<b>Norms and standards</b>	<b>39</b>

# 1 Safety

## 1.1 Safety use

- Before using your coffee machine, please read the safety instructions and all of the information in this manual first and keep it for future reference.
- Be careful! This machine serves hot drinks. Don't reach beneath the dispensing nozzles and hot water spout after selection and during dispensing.
- If a fault occurs, disconnect the machine from the electricity supply and from the water supply.
- This appliance can be used by children aged 8 years and above and persons with reduced physical, sensory or mental capabilities or lack of experience and knowledge if they have been given supervision or instruction concerning use of the appliance in a safe way and they understand the hazards involved. Children shall not play with the appliance. Cleaning and user maintenance shall not be done by children without supervision.
- The machine may only be in locations where it can be overseen by trained personnel.

## 1.2 Installation

- Installation, transportation and adjustment of the machine should only be carried out by properly trained service personnel. Their instructions for transportation, unpacking and installation of the machine, are available in the technical manual.
- Check the appliance for transport damage. Do not connect a damaged machine.
- The machine is not suitable for outdoor use.
- Do not install the machine in an area where a water jet or similar device could be used.
- Place the machine on a level surface in a hygienic dry room, with a temperature between 5°C and 35°C. (40°F - 95°F)
- Do not use an extension cord.
- Only hose-sets according to IEC 61770 may be used for the connection to the water supply.

## 1.3 Maintenance

- Regular cleaning according this manual is needed to ensure hygienic operation.

- The appliance shall not be cleaned by a waterjet.
- Do not use water in or near the machine unless the instructions explicitly give direction to do so.
- Do not use aggressive cleaning products or abrasives to clean (parts of) the machine.
- If the power cord is damaged, it must be replaced by the manufacturer, its service agent or similar qualified persons in order to avoid a safety issue.

## **1.4 Extended down time**

- If the machine will not be used for a longer period of time (for example during the holidays) it is recommended to switch off the water supply and the electricity. The main on/off switch is located at the rear side of the machine.
- In areas where the temperature can drop below freezing, the boilers must be emptied. Contact technical support of the supplier.
- When freezing has occurred, please contact the technical support of your supplier.





## 2 Description of the machine

### 2.1 General

This is a fully automatic single cup machine for coffee, café crème, espresso, cappuccino, macchiato and hot water. Always place a cup before selecting a drink from the touchscreen. You can adjust for weaker or stronger taste in the selection menu. Your supplier can make further adjustments to the strength and sizes of the drinks.

### 2.2 The machine exterior and interior

See the **fold out** in the back of this guide. The exterior and interior numbers and letters correspond with the numbers or letters between the brackets ( ) in the text.

### 2.3 Display and selections

The machine can be operated using the touchscreen panel (6) on the door. By pushing one of the selection buttons on the screen, a product choice can be made. Before you dispense a beverage, a cup must be placed under one of the outlets.

### 2.4 Type plate

See fold out for location of the type plate (F).

The type plate shows:

- Manufacturer.
- Serial number.
- Type/model specification.
- Date of production.
- Water connection.



## 3 Using the Nio

### 3.1 Switch on

- 1 Check if the water supply is turned on.
- 2 Press the on/off switch (14) at the rear side of the machine. The coffee machine switches on and heats up.

### 3.2 Switch off

The on/off switch (14) is located at the rear side of the machine.

- 1 Press 'O' to switch off the machine.
- 2 If the machine will not be used for a longer period of time, it is recommended to turn off the water supply.
- 3 See also chapter 1.4 'Extended down time'.

### 3.3 Preparing a drink

- 1 Place cup under outlet.
- 2 Adjust the height of the coffee outlet (9) to the size of your cup. The maximum height of a cup is 135 mm / 5.3 in. Fig. 2.
- 3 Select a beverage by pushing one of the buttons on the touchscreen.
- 4 If a pull down arrow is shown in

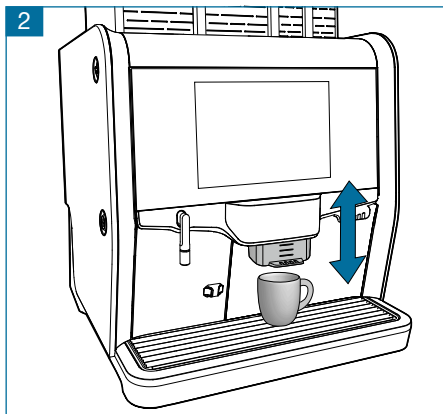
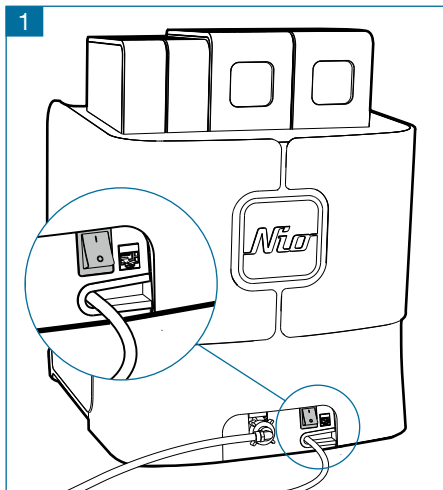



the bottom of the menu, more selections are available using this button.

- 5 If you want to change your selection, press the 'Cancel' button on the screen to return to the main menu.
- 6 If available, you may set the strength of your beverage using the buttons in the selection menu, then press the 'Start' button.
- 7 After the cup is filled, the machine will signal 'beep' and the screen will indicate 'Ready, take your cup'.
- 8 You can stop the process anytime by pressing the 'Stop' button on the screen.

### 3.4 Number selection

Option

Each selected drink has its own code. Using this code you can directly select a drink with the 'Number selection' function. This code is displayed in the menu when preparing the drink.

- 1 In the main menu select the button 'Number selection'.
- 2 Enter the beverage code.
- 3 Press 'Start'.

### 3.5 Filling the ingredients

Ingredient canisters can be filled without opening the door of the Nio. When filling, the canisters (2) can remain in the machine. Just open the lid (1) of the canister and start filling.

- Do not fill canisters further than necessary for one or two days. This will keep the ingredients fresh.
- Each canister is intended for a specific ingredient. The ingredient is shown on a text label on the canister. Use ingredients which are recommended by the supplier of the machine.
- To remove the canister see chapter 5.3.

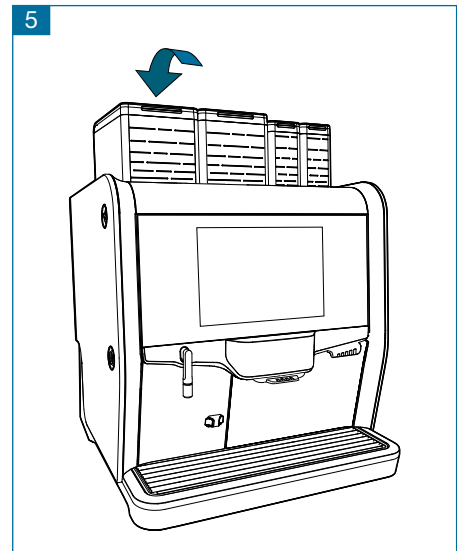

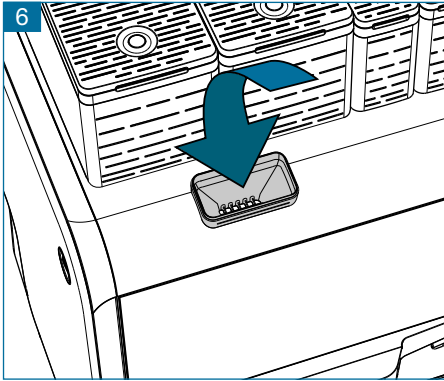

### 3.6 Manual ground coffee insert

Option

The optional manual ground coffee inlet is used for decaffeinated and special coffee types.

- 1 Touch the 'Manual coffee insert' button on the screen.
- 2 Open the manual ground coffee inlet (4).
- 3 Insert the desired amount of coffee.
- 4 Close the manual ground coffee inlet.
- 5 Press 'Start'.

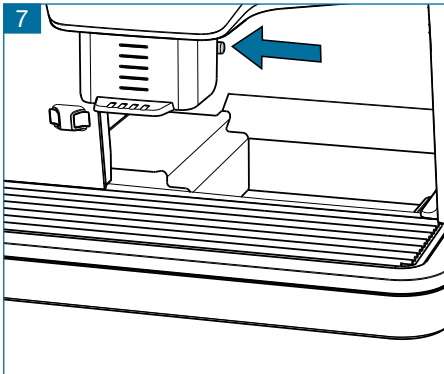

### 3.7 Connect the fresh milk

Option

- 1 Slide the adjustable outlet (9) to the top position.
- 2 Remove the waste bucket (11).
- 3 Slide the adjustable outlet to the bottom position.
- 4 Remove the milk frother assembly (10) by pushing the lock pin on the right hand side of the adjustable outlet and catch the milk frother. Fig. 7.
- 5 Remove the cover from the pump unit (15) and connect the milk hose to the pump connections, with the text 'UP' visible from the top side.
- 6 Connect the inlet piece to the

- shortest part of the milk hose and route it through the hole into the refrigerator (16).
- 7 Route the longest part of the milk hose through the hole in the right side of the machine. Fig. 8.
  - 8 Disassemble the milk frother from the holder and route the hose through the hole in the holder. Connect the hose with the milk frother. Fig. 9.
  - Reassemble the frother in the holder.
  - 9 Mount the milk frother assembly by moving it upward in the locking mechanism of the adjustable outlet (9). Fig. 10.
  - 10 Slide the adjustable outlet down to the bottom position.
  - 11 Gently pull the hose and route the milk hose into the slot at the bottom of the right hand part of the outlet bracket. Fig. 11.
  - 12 In the refrigerator, open the milk container and place the milk tube in the milk container. Only use UHT milk!

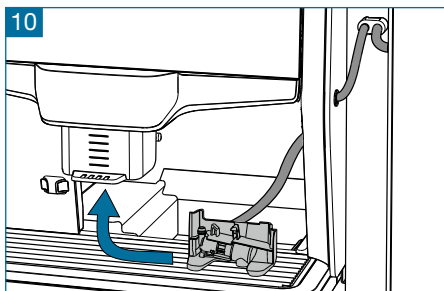
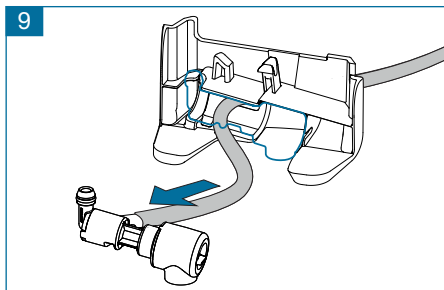
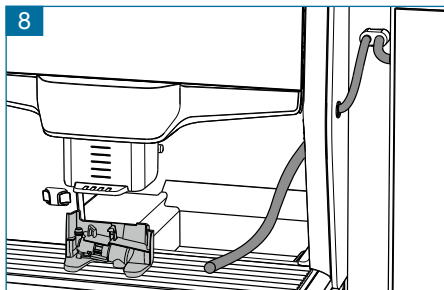



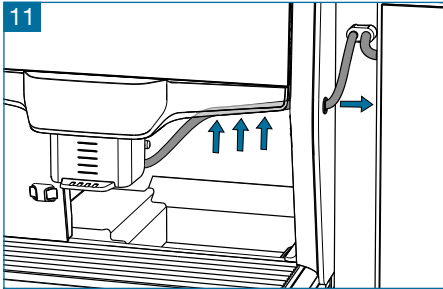

Option

- 13 Close the refrigerator (16).
- 14 Replace the cover on the pump unit (15).
- 15 Slide the outlet to the top position and replace the waste bucket (11).

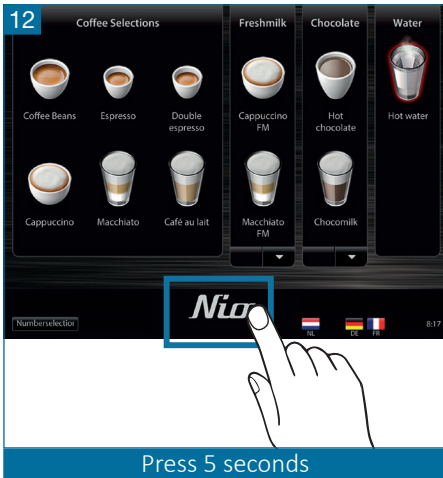

### 3.8 Service menu

The service menu can be entered by either opening the door or by pressing the logo at the bottom of the screen (6) for about 5 seconds. Fig. 12. Keep in mind that the logo in your situation may be different. From the service menu, the daily cleaning can be started (see chapter 5.1) and product counters can be read (see chapter 4.1).

## 4 Information

### 4.1 Reading out the counters

- 1 Enter the service menu by pressing and holding the logo at the bottom of the screen for about 5 seconds.
- 2 From the service menu, select 'Beverage counters'.
- 3 The display now shows the 'Free counter', 'Paid counter' and 'Total counter'.
- 4 Select 'Exit' and 'Press here to quit service' to return to the main menu.

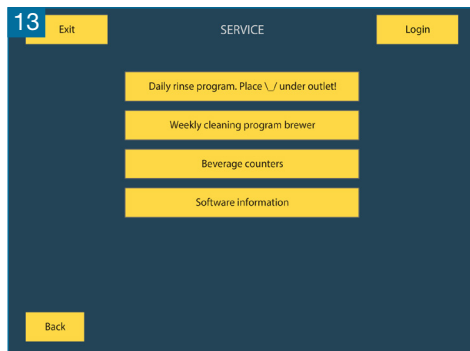



## 5 Maintenance and cleaning

### 5.1 Daily maintenance

Performing daily maintenance will ensure the quality of your beverages and a proper operation of the machine.

Daily maintenance can be performed without opening the door of the machine.

To perform the daily maintenance the following items are needed:

- \ / as delivered with the hygiene kit.
- A soft damp cloth.
- A jug, minimum 0.6 l / 20 fl oz.
- Milk frother cleaning liquid; De Jong Duke part number 4INF011.

Option

#### Step 1. Refill

Check if there are still enough ingredients in the canisters (2).

If necessary, fill up the canisters.

Ingredient canisters can be refilled without opening the door of the machine.

Do not fill canisters more than necessary for one or two days. This will keep the ingredients fresh.

15

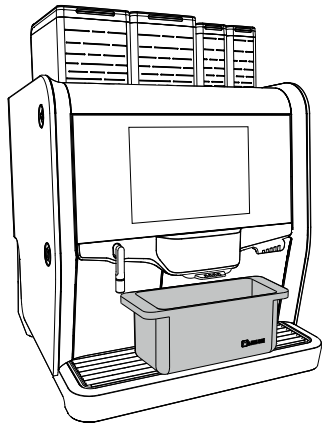

## Step 2. Rinsing mixers and CoEx® brewer

- 1 Place a  $\surd$  underneath the dispensing nozzle to collect the hot water.
- 2 Press and hold the logo at the bottom of the screen for about 5 seconds to enter the Service menu.
- 3 Press the 'Daily rinse program' button on the screen. Hot water from the boiler flows through the brewer and mixers.
- 4 Repeat this until clean water comes out of the dispensing nozzles.

16



Press 5 seconds

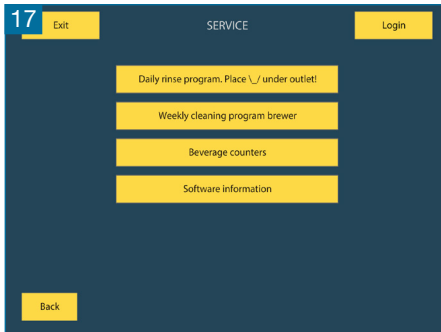

17



### Step 3. Cleaning optional milk system

If your Nio is equipped with the fresh milk option, the milk system should be cleaned daily.

For best results clean the milk system at the end of the day so that no milk will remain in the system over night or during the weekend.

- 1 Prepare a solution of 30ml / 1 fl oz milk system cleaner (4INF011) with half a liter / 17 fl oz cold water in a jug.
- 2 Open the refrigerator, take the milk tube from the milk container and place it in the jug with the cleaning solution.
- 3 Press and hold the logo at the bottom of the screen for about 5 seconds to enter the Service menu. Another way to enter the Service menu is to open and close the door.
- 4 Press the 'Cleaning program milk system' button on the screen.
- 5 Follow the instructions on the screen:
  - a Place a  under the outlet.
  - b Press the 'Press HERE to start the cleaning' button on the screen.
  - c The cleaning solution will be pumped through the milk system into the .

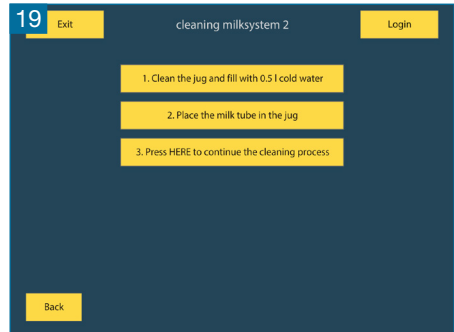
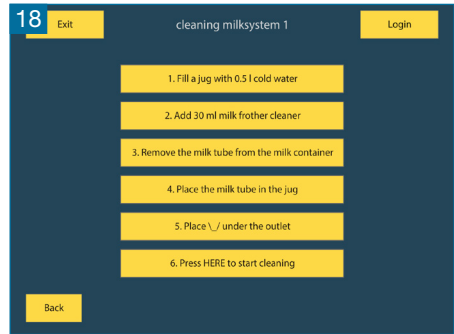

- d When instructed by the screen, clean the jug and fill it with clean cold water.
  - e Place the milk tube in the jug again.
  - f Press the 'Press HERE to continue the cleaning' button on the screen.
  - g The system will be rinsed out with clean water.
- 6 After returning to the service menu, replace the milk tube from the jug to the milk container.
  - 7 Close the refrigerator.
  - 8 Select 'Exit' and 'Close door and press here to quit service' to return to the main menu.

20

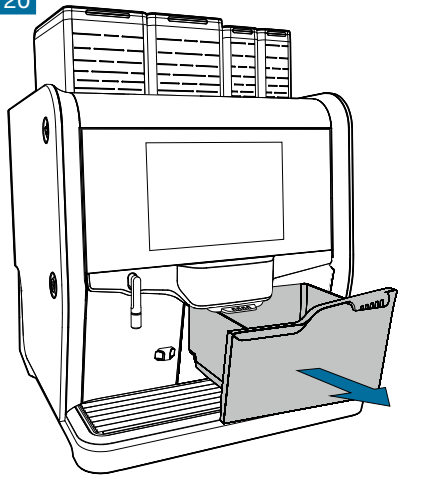

#### Step 4. Cleaning the waste bucket

- 1 Slide the adjustable outlet (9) to the top position.
- 2 Remove the waste bucket (11).
- 3 Empty it and rinse it with warm water.
- 4 Replace the waste bucket.

### Step 5. Cleaning the drip tray

- 1 Remove the external drip tray (13) and the drip grid.
- 2 Rinse the drip tray and grid in warm water.
- 3 Install the drip tray and grid.

### Step 6. Cleaning the exterior

Clean the outside of the machine with a soft damp cloth.

Do not use a water jet or similar device for cleaning, it will possibly damage the machine.

### Step 7. Back to operation

- 1 Select 'Close door and press here to quit service' to return to the main menu.
- 2 Take a test drink.
- 3 The machine is ready for use now.

21

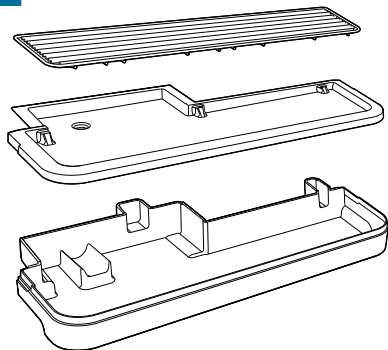



## 5.2 Weekly maintenance

Performing weekly maintenance will ensure the quality of your beverages and a proper operation of the machine.

For weekly maintenance the door of the machine needs to be opened.

A hygiene kit is delivered with the machine. This allows you to exchange the parts, which need to be cleaned.

To perform the weekly maintenance the following items are needed:

- Door key.
- Cleaning pill; De Jong DUKE part number 4INF009.
-  as delivered with the hygiene kit.
- Hygiene kit with internal maintenance parts.
- A soft damp cloth.
- A jug, minimum 0.6 l / 20 fl oz.
- Milk frother cleaning liquid; De Jong DUKE part number 4INF011.
- Brushes as delivered with the machine.

Option

### Step 1. Refill

Check if there are still enough ingredients in the canisters (2).

If necessary, fill up the canisters.

Product canisters can be refilled without opening the door of the machine.

Do not fill canisters more than necessary for one or two days. This will keep the ingredients fresh.

## Step 2. Run a cleaning program for the CoEx® brewer

- 1 Insert tablet through pill entry (left side of machine). Fig 22.
- 2 Place a  $\surd$  underneath the dispensing nozzle to collect the hot water.
- 3 Press 'Start' to start the cleaning cycle.

22

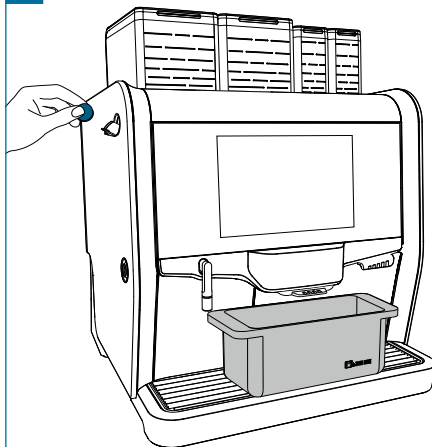

## Step 3. Cleaning optional milk system

If your Nio is equipped with the fresh milk option, the milk system should be cleaned daily.

Preferably clean the milk system at the end of the day so that no milk will remain in the system over night or during the weekend.

- 1 Prepare a solution of 30ml / 1 fl oz milk system cleaner (4INFO11) with half a liter / 17 fl oz cold water in a jug.
- 2 Open the refrigerator, take the milk tube from the milk container and place it in the jug with the cleaning solution.
- 3 Press and hold the logo at the bottom of the screen for about 5 seconds to enter the Service menu.

23



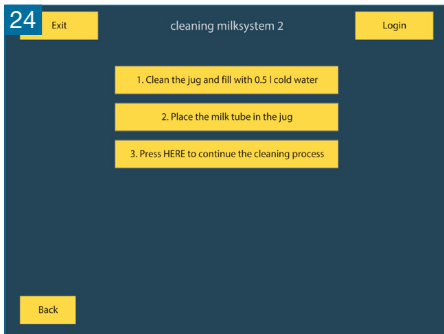

Option

- Another way to enter the Service menu is to open and close the door.
- 4 Press the 'Cleaning program milk system' button on the screen.
  - 5 Follow the instructions on the screen:
    - a Place a  $\surd$  under the outlet.
    - b Press the 'Press HERE to start the cleaning' button on the screen.
    - c The cleaning solution will be

Option

- d pumped through the milk system into the  $\surd$ .
- d When instructed by the screen, clean the jug and fill it with clean cold water.
- e Place the milk tube in the jug again.
- f Press the 'Press HERE to continue the cleaning' button on the screen.
- g The system will be rinsed out with clean water.
- 6 After returning to the service menu, replace the milk tube from the jug to the milk container.
- 7 Close the refrigerator.
- 8 Select 'Exit' and 'Close door and press here to quit service' to return to the main menu.

#### Step 4. Removing parts; coffee funnel, canister outlets, mixers, dispensing nozzles.

- 1 Unlock and open the door.
- 2 Remove the green coffee funnel (B). Fig. 25.
- 3 Remove the canister outlets (C) from the canisters by pulling them towards you. Fig. 26.
- 4 Remove the hoses from the mixers (E).
- 5 Turn the green part counter clock wise and pull the mixers towards you. Fig. 27 and 28.
- 6 Remove the green exhaust drawers. Fig. 29.
- 7 Take the green dispensing nozzles (K) out of the outlet holder (L) by pressing them from the bottom side in upward direction and detach the CoEx® outlet hose (G) and the mixer hoses (I). Fig. 30.
- 8 Remove the grey outlet holder (L) by moving it towards you. Fig. 31.

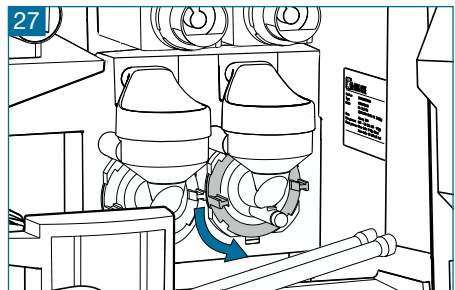
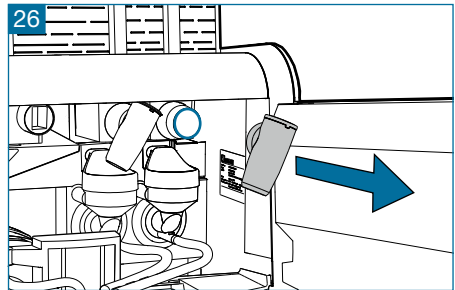
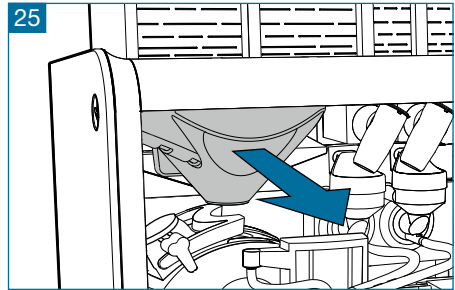

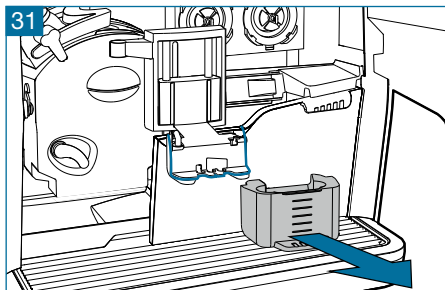
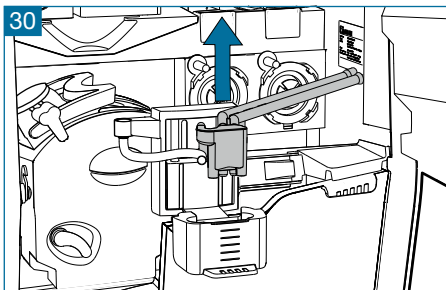
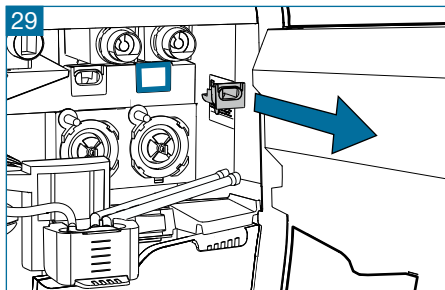
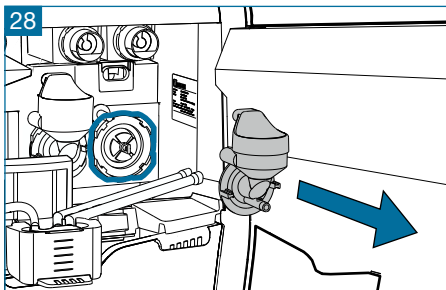

## Step 5. Cleaning optional fresh milk parts

- 1 Slide the adjustable outlet (9) to the top position.
- 2 Remove the waste bucket (11).
- 3 Push the lock pin on the right hand side of the adjustable outlet and catch the milk frother. Fig. 32.
- 4 Detach the hose from the milk frother and disassemble the milk frother from the holder. Fig. 33.
- 5 To clean, disassemble the parts from the milk frother:
  - a Pull the outlet part from the middle part (pull before turning as it is locked with a small positioning tab).
  - b Pull the steam inlet from the middle part (pull before turning as it is locked with a small positioning tab).

*Using the hygiene kit parts the cleaning can be done after the machine has been put in operation again with the parts from the kit.*

- 6 Prepare a solution of 30ml / 1 fl oz milk system cleaner (4INFO11) with half a liter / 17 fl oz cold water in a jug and immerse all fresh milk

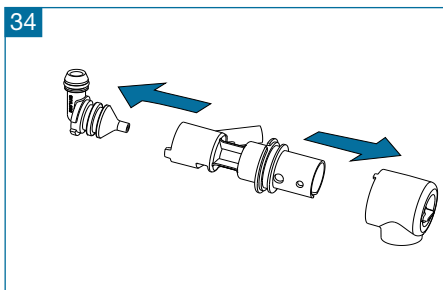
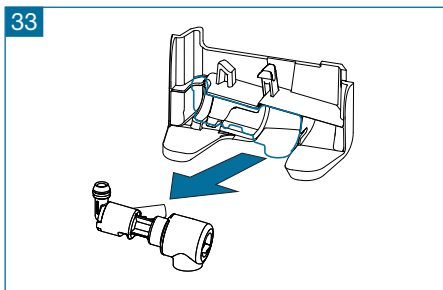
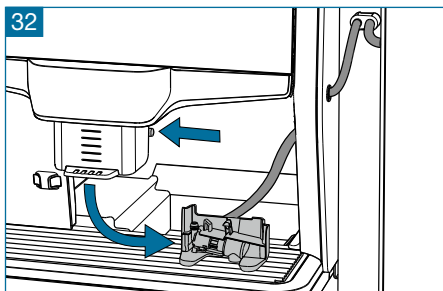

35

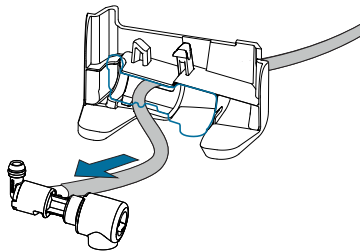

36

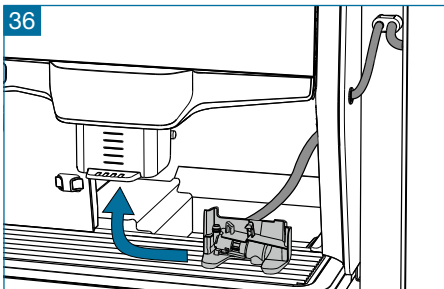

37

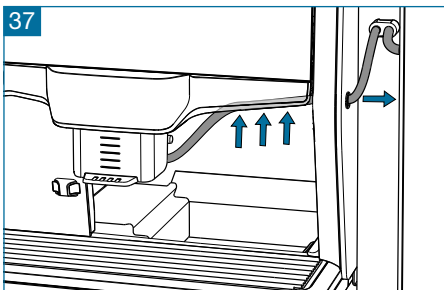

Option

parts. After 4 hours clean all parts properly with a brush and clean water thoroughly.

- 7 Make sure all residues are removed.
- 8 Reassemble the milk frother in reverse order and make sure to position the small positioning tabs into the corresponding openings.
- 9 Route the hose through the hole in the holder. Connect the hose with the milk frother. Fig. 35. Reassemble the frother in the holder.
- 10 Mount the milk frother assembly by moving it upward in the locking mechanism of the adjustable outlet (9). Fig. 36.
- 11 Slide the adjustable outlet down to the bottom position.
- 12 Gently pull the hose and route the milk hose into the slot at the bottom of the right hand part of the outlet bracket. Fig. 37.

## Step 6. Cleaning the CoEx® brewer internal drip tray and waste bucket.

- 1 Remove the waste bucket (11).
- 2 Empty it and rinse it with warm water.
- 3 Turn the outlet bracket (H) to the right so that the CoEx® brewer (J) can be taken out. Fig. 38.
- 4 Remove the brewer by lifting the green fixation handle and pulling the brewer towards you at the same time. Fig. 39.
- 5 Remove the internal drip tray (M) that is located under the CoEx® brewer. Fig. 39.
- 6 Rinse out the brewer and the drip tray with warm water while cleaning it with a brush.
- 7 Dry the internal drip tray.
- 8 Replace the brewer and the internal drip tray.
- 9 Replace the waste bucket (11).

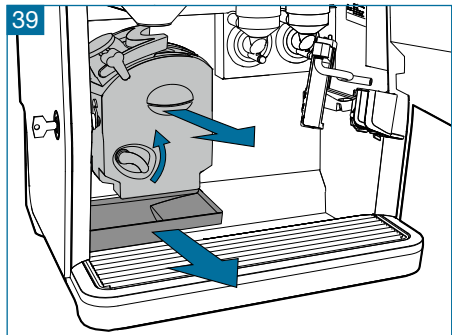
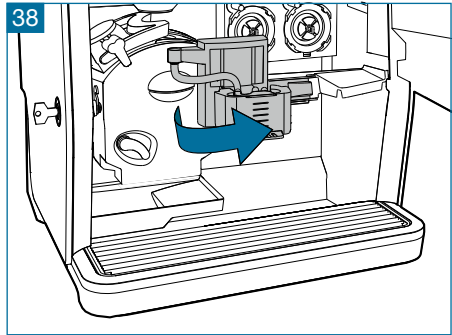

## Step 7. Rinsing the parts.

*When using the parts of the hygiene kit this can be done immediately after the machine has been put in operation again.*

- 1 Rinse out all loose parts in hot water.
- 2 Open up the green drawers to remove the powder.
- 3 Make sure the coffee funnel and canister outlets are completely dry before replacing them.



## Step 8. Replacing parts in the machine; dispensing nozzles

*The use of the clean and dry parts from the hygiene kit is preferred.*

- 1 Replace the grey outlet holder (L) by sliding it over the metal outlet arm.
- 2 Connect the mixer hoses (I) and the CoEx® hose (G) to the green dispensing nozzles (K).
- 3 Replace the green dispensing nozzles in the grey holder (L).
- 4 Replace the green exhaust drawers.
- 5 Assemble the mixing system (E) in reversed order of disassembling.
- 6 Replace the canister outlets (C).
- 7 Replace the green coffee funnel (B).

## Step 9. Cleaning the drip tray

- 1 Remove the external drip tray (13) and the drip grid.
- 2 Rinse the drip tray and grid with warm water.
- 3 Install the drip tray and grid.

## Step 10. Back to operation

- 1 Close the door.
- 2 Select 'Close door and press here to quit service' to return to the main menu.
- 3 Take a test drink.
- 4 The machine is ready for use now.

## 5.3 Monthly maintenance

Performing monthly maintenance will ensure the quality of your beverages and a proper operation of the machine. For monthly maintenance the door of the machine needs to be opened.

In addition to daily and weekly maintenance perform the following steps monthly:

### Step 1. Removing the canisters

- 1 Unlock and open the door.
- 2 Remove the green coffee funnel (B).
- 3 Remove the canister outlets (C) from the canisters by pulling them towards you. Fig. 40.
- 4 Pull the green locking handles underneath the bean canisters and remove the canisters.
- 5 Push the snap locks underneath the instant and/or ground coffee canisters and remove the canisters. Fig. 41.
- 6 Empty all canisters.

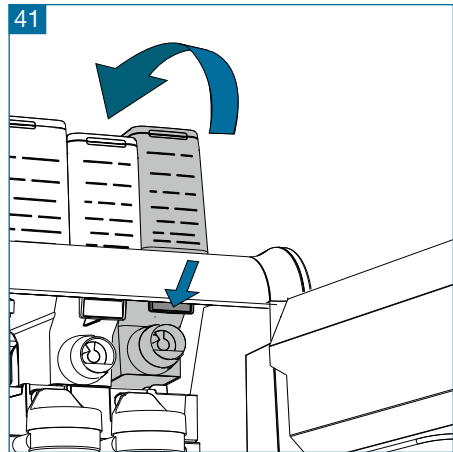
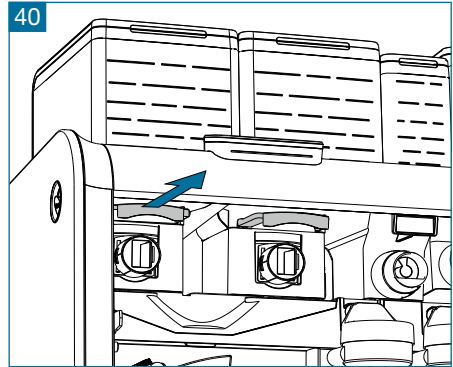

### Step 2. Cleaning the canisters

- 1 Rinse out the canisters with warm water until all ingredient residue is removed.
- 2 Dry the canisters very thoroughly on the inside and outside.
- 3 Do not fill the canisters unless they are completely dry! Otherwise the ingredients may form lumps, which makes the system unusable.

### Step 3. Reinstalling the canisters

- 1 Fill the canisters and place them back into the machine.
- 2 The canisters have their own position in the machine. These positions are marked by text labels which corresponds to the text labels on the canisters.
- 3 The instant and/or ground coffee canisters automatically snap into place and the bean canisters must be locked by pushing the green handles.
- 4 Replace the coffee funnel (B) and the canister outlets (C).

## 5.4 Yearly maintenance (only for optional fresh milk system)

*Option*

We advise to replace yearly the following parts:

- Milk hose from pump to milk container and milk frother; de Jong DUKE part number 5RSL015.
- Milk frother; de Jong DUKE part number 6VUL129.

## 6 Messages

If these messages persist after taking the action described below, contact your technical service representative.

<b>Message</b>	<b>Action</b>
Clean the milk system	Clean the milk system. See chapter 5.1.
Close the door	Close the door.
Communication error	Consult technical support.
Empty the driptray	Empty the drip tray. See chapter 5.1.
Empty waste bucket	Empty waste bucket. See chapter 5.1.
Grinder blocked	Contact the operator.
Heating boiler	Wait until boiler is heated.
Install driptray	Install driptray. See chapter 5.1.
Install on position 1: Coffee Beans	Install Coffee Beans canister. See chapter 5.3.
Install on position 2: Espresso Beans	Install Espresso Beans canister. See chapter 5.3.
Install on position 3: Chocolate canister	Install Chocolate Beans canister. See chapter 5.3.
Install on position 4: Topping canister	Install Topping canister. See chapter 5.3.
Insufficient water amount detected	Consult technical support.
Mixer blocked	Contact the operator.

<b>Message</b>	<b>Action</b>
No water connected	Open/connect the water connection and restart the machine.
No water level detected in pressure boiler	Consult technical support.
Place coffee funnel in the machine	Open door en place coffee funnel. See chapter 5.2.
Place cup in center	Place cup under center outlet. See chapter 3.3.
Place cup left	Place cup under left outlet.
Place wastebucket	Place wastebucket. See chapter 5.2.
Remove and place the brewer	Remove and place the brewer. Order coffee drink. If message appears again, consult technical service.
Replace waterfilter	Contact the operator.
Rinse brewer with tablet	Run cleaning cycle for the CoEx <sup>®</sup> brewer. See chapter 5.2.
Shortcut temperature sensor	Consult technical support.
Startup problem	Consult technical support.
Temperature boiler too high	Consult technical support.
Temperature sensor disconnected	Consult technical support.
Wait until pressure boiler is filled	Wait until pressure boiler is filled.
Waste bucket full	Empty waste bucket. See chapter 5.2.
Waterfilter installed ?	Consult technical support.

## 7 Technical specifications

### Dimensions:

---

Width	460 mm / 18.1 inches
Height	599 mm / 23.6 inches
Depth	540 mm / 21.3 inches
Weight	(empty) 35 kg / 77 lbs

### Electrical connection:

---

120 VAC, 60 Hz, 1.3 kW

220-240 VAC, 50-60 Hz, 1.5-1.8 kW (limited power setting, contact your supplier)

220-240 VAC, 50-60 Hz, 2.9-3.4 kW

### Water line pressure:

---

Minimum 90 kPa (0.9 bar) / 13 psi

Maximum 1.0 MPA (10 bar) / 145 psi

### Rated pressure:

---

Water boiler 1.1 MPa (11 bar) / 160 psi

Steam boiler 0.5 MPa (5 bar) / 72 psi

### Noise level:

---

Standby 0 dB(A).

Beverages using whole beans < 63 dB(A).

### Ambient temperature:

---

Storage 5 - 50°C / 40 - 120°F

Operating 5 - 35°C / 40 - 95°F

## 8 Norms and standards

The machine bears the CE marking and complies with the following directives/regulations:

- 2006/42/EC Directive on machinery
- 2006/95/EC Low voltage directive
- 2004/108/EC Directive EMC
- (EG) 1935/2004 Regulation on food contact materials
- 98/83/EG Directive on the quality of water
- 2011/65/EU Directive ROHS

The machine complies with the following standards:

- IEC 60335-1 Safety of household and similar appliances
- IEC 60335-2-75 Particular requirements for dispensing appliances and vending machines
- EN 61000-6-3 Radiated and conducted immunity up to 1 GHz
- EN 61000-6-1 Radiated and conducted immunity up to 2.7 GHz
- EN 61000-4-2 ESD
- EN 61000-4-3 HF immunity
- EN 61000-4-4 EFT
- EN 61000-4-5 Surge
- EN 61000-4-6 CDN/clamp injection
- EN 61000-4-8 Power Magnetic field
- EN 61000-4-11 Dips and voltage fluctuations
- EN 61000-3-2 Harmonic currents
- EN 61000-3-3 Flicker

The manufacturer of this machine is:

de Jong DUKE Europe

Bruningsstraat 1  
3364 AA Sliedrecht  
The Netherlands

Telephone: +31 (0) 184 496767

Fax: +31 (0) 184 416059

[www.dejongduke.nl](http://www.dejongduke.nl)  
[info@dejongduke.nl](mailto:info@dejongduke.nl)

de Jong DUKE North America

12680 Delta Street  
Taylor, MI, 48180  
U.S.A.

Telephone: +1 734 403 1708

Fax: +1 734 403 1712

[www.dejongduke.com](http://www.dejongduke.com)  
[info@dejongduke.com](mailto:info@dejongduke.com)

## Original instructions

Copyright © 2014, J.M. de Jong Duke Automatenfabriek B.V.

All rights reserved.

Although this user manual has been written with the utmost care, De Jong DUKE Automatenfabriek B.V. accepts no liability for inaccuracies or omissions. No liability is accepted for the consequences due to operation of the equipment in accordance with the information contained in these instructions.

J.M. de Jong DUKE Automatenfabriek B.V. reserves the right to alter the specifications and the information in this manual at any time and without prior notification to the purchaser. No part of this publication may be stored in a retrieval system, or transmitted, in any form or by any means without prior permission of the publisher.





Coffee selections

Coffee	Espresso
CremaRich	Single Espresso

Specialty drinks

Mocha	Coffee Latte
Flatwhite	Cappuccino

Chocolatey treats

Hot White	Hot Chocolate
Latte Macchiato	



Café au Lait    Hot Chocolate    Hot Water  
Chocomilk    Cold Water



## Exterior of the Nio

- 1 Bean canister lid
- 2 Bean canister
- 3 Instant canister
- 4 Manual ground coffee inlet
- 5 Entrance cleaning pill
- 6 Touchscreen
- 7 Door lock
- 8 Hot water outlet
- 9 Adjustable outlet
- 10 Fresh milk frother (Option)
- 11 Waste bucket
- 12 Cup sensors
- 13 External drip tray
- 14 On/off switch
- 15 Pump unit (Option)
- 16 Refrigerator (Option)
- 17 

## Interior of the Nio

- A Grinder
- B Coffee funnel
- C Canister outlet
- D Brewer outlet
- E Mixer
- F Type plate
- G CoEx® hose
- H Outlet bracket
- I Mixer hoses
- J CoEx® brewer
- K Dispensing nozzles
- L Outlet holder
- M Internal drip tray

